

Flogo 48"

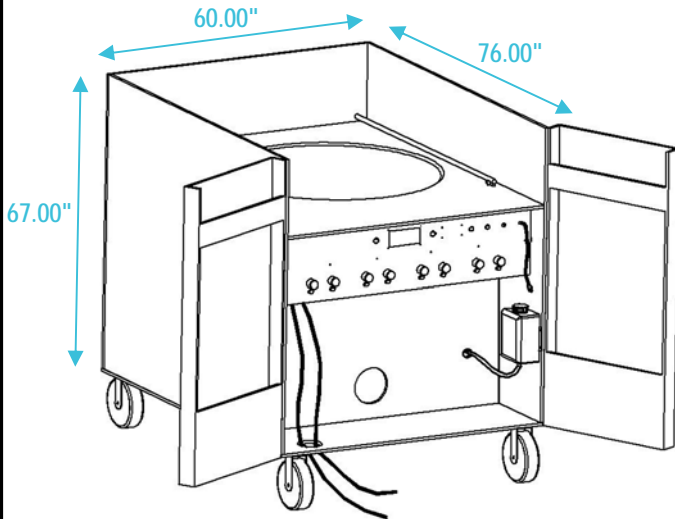

Flogo® 48" Generator Dimensions



Flogo® 48" Stencil Dimensions

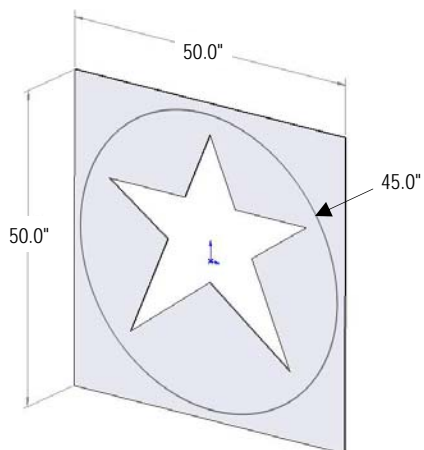

Specifications for 48"

Size of Unit: 60in/1.52m L x 76in/1.93m W x 67in/1.70m H (including wheels).

Shipping Weight: 350 lbs/158.76 kg, without fluid. 670 lbs /303.91 kg, with fluid.

Material: Wood covered ABS road case.

Electrical Requirements:

Two 20 Amp, 110V circuits per machine.

Also available in 100V, 220V, and 12V DC (by request).

Priming Time: 10-15 minutes.

Noise Levels: 58db @ 3 meters.

FPM = Flogos® Per Minute:

Depends on the desired thickness. On average, one every 40 to 50 seconds.

Colors Available: Black.

Flogo® Machine Controls:

This machine is semi automatic. Operator must watch the rate of Flogos® per minute. Available timer control settings: 5 seconds - 60 seconds.

Required External Gases:

Flogo® requires a constant flow of helium and compressed air.

Air Compressor: A steady 50 PSI/3.44 Bar @ 6 SCFM/169.92 L/min

Helium Usage:

NOTE: These calculations are for an average helium setting of 2.

1 head @ 16 cubic ft/hr (7.5 L/min) X 5 heads (on Flogo® 48")
= 80 cubic ft/hr (2.26 cubic m/hr)

For a 300 cubic foot (8.4 cubic meter) helium tank:
300 / 80 = 3.75 hours of use (@ setting 2)

Custom Flogos® must adhere to sample guidelines.



256-229-5551
800-745-8599

www.flogos.net